

# Servo Cylinder

## SQ-D-61-U

### Square Automation

Contact : + 91 965733 2859 (Pune, MH)  
+ 91 98501 72779

Email : [square.automation@gmail.com](mailto:square.automation@gmail.com)

Web : [www.square-automation.net](http://www.square-automation.net)

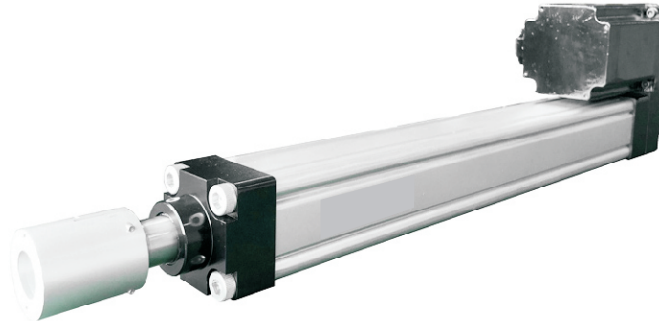

### Features

- Micro cylinder bore, small in size
- High speed and flexibility
- Robust and strong, high reliable
- Self locking for no motion during sudden electricity cut off
- High Precision in Positioning
- High Service life over 10,000Km, one year warranty

### ■ Specifications

Motor Power (W)	400	750
Motor rated torque (Nm)	1.3	2.4
Drive Type	Grinding ballscrew	
Position Repeatability (mm)	± 0.02	
Screw lead (mm)	5 & 10	5 & 10
Max Speed (mm/sec)	250 & 500	250 & 500
Thrust (KG)	141 & 70	260 & 130
Max Thrust (KG)	400	400
Max Stroke length (mm)	1000	1000

## ■ Drawing

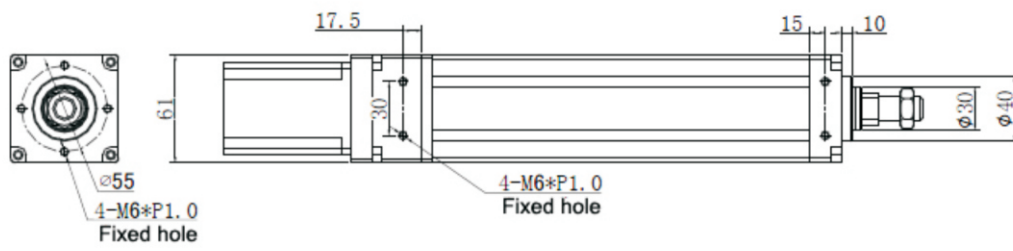
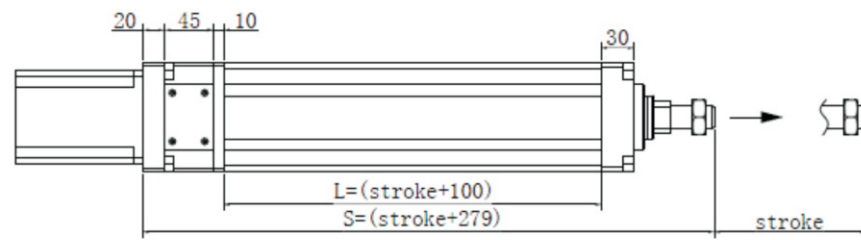
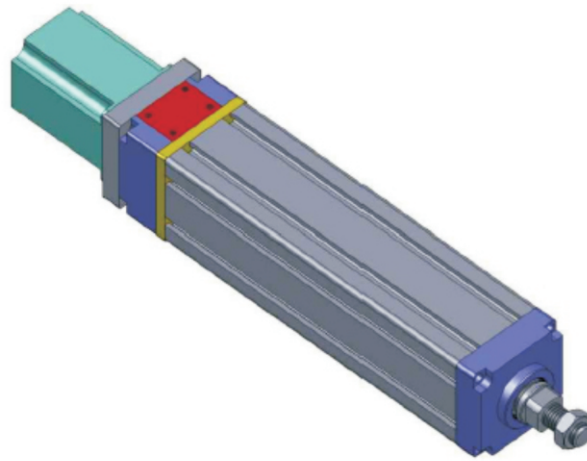

## ■ Applications

