



# Servo Cylinder Testing

J TYPE MACHINE SERIES



[Square.automation@gmail.com](mailto:Square.automation@gmail.com)



[Squareautomation.co.in](http://Squareautomation.co.in)



+ 91 965733 2859 / 94225 48391

# Features:

The J series servo presses are designed in a four-column modular design. The utility model has the advantages of simple structure, economy and practicability, good rigidity, high precision, strong ant offset capability, rich and varied accessories, free combination, flexibility and variety. Thereby saving costs for customers.

Sr. No	Specifications	J Series	Unit
1	Model No	SQ-J-10	
2	Pressure Force Range	$\leq 10$	KN
3	Speed	$\leq 50$	Mm/sec
4	Stroke	Max 300	Mm
5	Position Repeatability	0.05	Mm
6	Load Accuracy	1	%
7	Working Temperature	0 to 60	°C

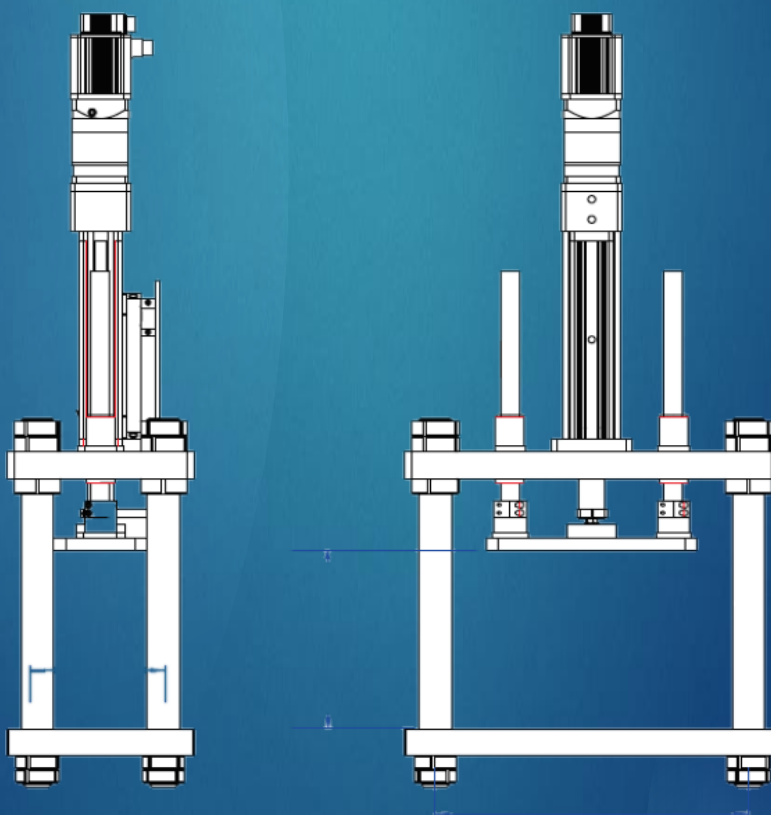

# Applications

- Press-fitting
- Pressing
- Punching
- Clamping
- Bending
- Stamping
- Crimping
- Testing Springs
- Beveling
- Riveting
- Securing
- Deep Drawing
- Press Fitting Balls
- Clinching
- Straightening

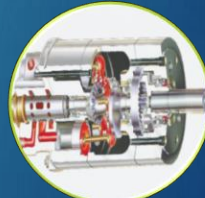
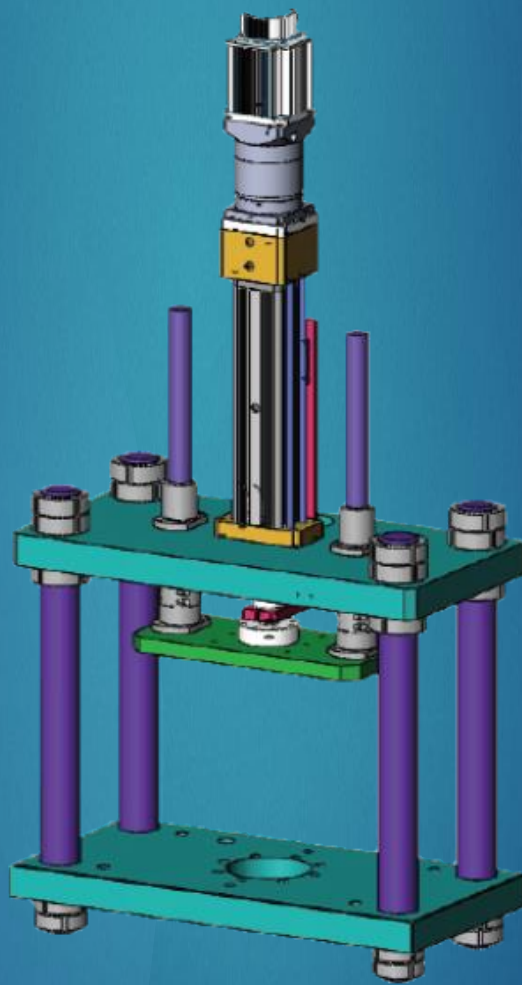

Square.automation@gmail.com



www.squareautomation.co.in



+ 91 965733 2859 / 94225 48391